

# LEAD WOOD SCREW STYLE

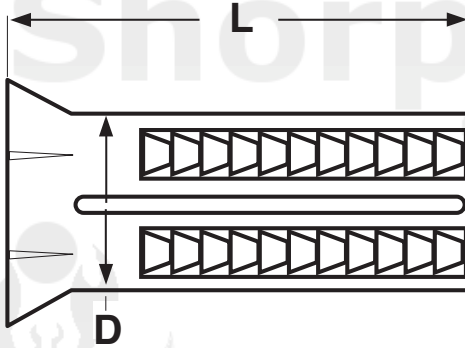

| LEAD WOOD SCREW ANCHOR |                       |                               |               | FF-S-325 Group IV, Type 1 |     |        |
|------------------------|-----------------------|-------------------------------|---------------|---------------------------|-----|--------|
| Wood Screw Size        | Fractional Screw Size | D<br>Nominal Outside Diameter | L<br>Lengths  | Proof Test Loads (pounds) |     |        |
|                        |                       |                               |               | Anchor Lengths (inches)   |     |        |
|                        |                       |                               |               | 3/4"                      | 1"  | 1 1/2" |
| 6                      | 1/8 - 3/16"           | 1/4"                          | 3/4, 1, 1 1/2 | 80                        | 88  | 100    |
| 8                      | 1/8 - 3/16"           | 1/4"                          | 3/4, 1, 1 1/2 | 88                        | 122 | 192    |
| 10                     | 3/16 - 1/4"           | 5/16"                         | 3/4, 1, 1 1/2 | 100                       | 160 | 540    |
| 12                     | 3/16 - 1/4"           | 5/16"                         | 3/4, 1, 1 1/2 | 104                       | 196 | 624    |
| 14                     | 1/4 - 5/16"           | 3/8"                          | 1, 1 1/2, 2   | 192                       | 360 | 800    |
| 16                     | 5/16"                 | 3/8"                          | 1, 1 1/2, 2   | ----                      | 380 | 900    |
| 18                     | 5/16"                 | 3/8"                          | 1, 1 1/2, 2   | ----                      | 412 | 940    |

|                                 |   |
|---------------------------------|---|
| <b>Description</b>              | A hollow, cylindrical anchor which is split from the bottom up for the majority of its length and has longitudinal ribs for part of its length. The diameter at the split (bottom) end is tapered; the top end is flared to a wider diameter than the remainder of the anchor's body. |
| <b>Applications/ Advantages</b> | Used with wood screws, lags and tapping screws for light duty applications in brick, block, drywall, masonry or concrete. Will conform to irregular, out-of-round holes.  |
| <b>Material</b>                 | Lead alloy  |
| <b>Anchor Spacing</b>           | Anchors should be installed a minimum of ten anchor diameters between each other and a minimum of five anchor diameters from the edge.  |
| <b>Depth of Hole</b>            | Should be at least 1/4" longer than the length of the anchor.   |
| <b>Tensile Strength</b>         | The suggested safe working load is one-fourth the average proof test loads shown in the above table.  |