

**HEAD DIMENSIONS** Oval, Phillips & Slotted

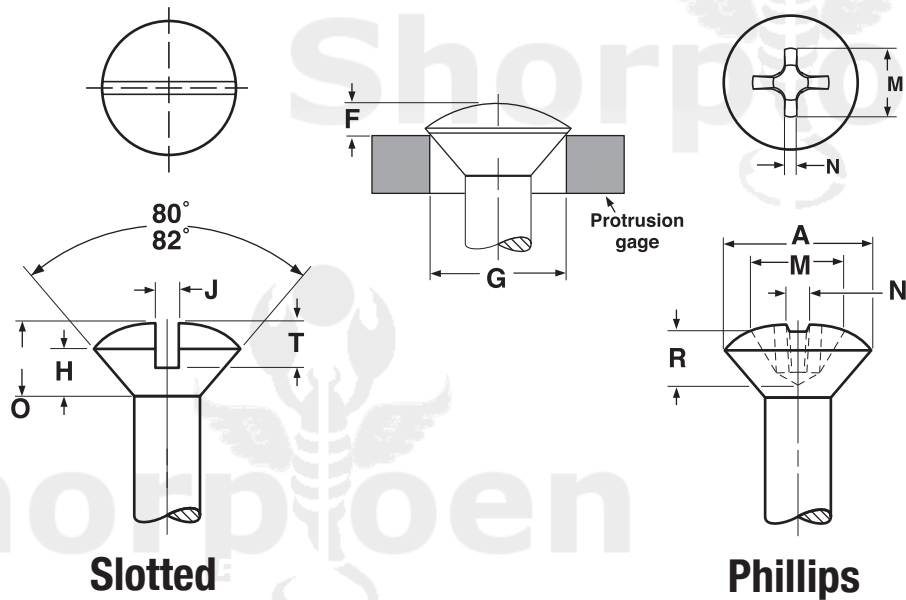

**Slotted**

**Phillips**

OVAL HEADS FOR MACHINE SCREWS														ASME B18.6.3-2013	
Nominal Size	A		H	O	J		T		M	R	N	F		G	Phillips Driver Size
	Head Diameter		Height of Head		Slot Dimensions				Recess Dimensions			Protrusion Above Gaging Diameter		Gaging Diameter	
			Side	Total	Width		Depth		Diam.	Depth	Width	Max	Min		
	Max	Min	Max	Max	Max	Min	Max	Max	Ref	Ref	Ref	Max	Min		
0	.112	.096	.035	.056	.023	.016	.030	.025	.068	.036	.014	.047	.031	.078	0
1	.137	.120	.043	.068	.026	.019	.038	.031	.070	.039	.015	.053	.035	.101	0
2	.162	.144	.051	.080	.031	.023	.045	.037	.106	.060	.018	.058	.039	.124	1
3	.187	.167	.059	.092	.035	.027	.052	.043	.118	.072	.019	.064	.044	.148	1
4	.212	.191	.067	.104	.039	.031	.059	.049	.130	.086	.019	.069	.048	.172	1
5	.237	.215	.075	.116	.043	.035	.067	.055	.152	.073	.028	.075	.053	.196	2
6	.262	.238	.083	.128	.048	.039	.074	.060	.172	.092	.030	.080	.057	.220	2
8	.312	.285	.100	.152	.054	.045	.088	.072	.186	.107	.031	.091	.066	.267	2
10	.362	.333	.116	.176	.060	.050	.103	.084	.202	.125	.033	.102	.075	.313	2
12	.412	.380	.132	.200	.067	.056	.117	.096	.264	.140	.038	.113	.084	.362	3
1/4	.477	.442	.153	.232	.075	.064	.136	.112	.284	.160	.040	.129	.095	.424	3
5/16	.597	.556	.191	.290	.084	.072	.171	.141	.384	.226	.065	.155	.117	.539	4
3/8	.717	.670	.230	.347	.094	.081	.206	.170	.404	.245	.068	.182	.139	.653	4
7/16	.760	.715	.223	.345	.094	.081	.210	.174	.416	.257	.070	.195	.150	.690	4
1/2	.815	.765	.223	.354	.106	.091	.216	.176	.430	.271	.071	.212	.163	.739	4