

THREAD FORMING SCREWS

DIN 7500 Trilobular Thread Rolling Screws

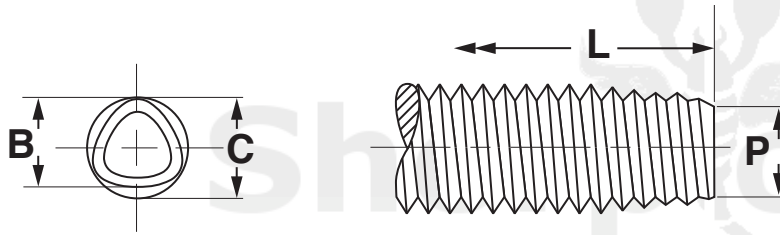

METRIC - TRILOBULAR THREAD ROLLING SCREWS											DIN 7500-1	
Nominal Size & Thread Pitch	C		B		P	Test Plate Thickness	Hole Diameter		Minimum Breaking Torque	Minimum Breaking Force	Maximum Screw-in Torque	
	Diameter of Circumscribing Circle		Major Thread Diameter		Point Diameter		Max	Min	Nm	N	Nm	
	Max	Min	Max	Min	Max							
M2-0.40	2.06	1.98	1.98	1.90	1.67	2.0	1.825	1.8	0.4	1650	0.3	
M2.5-0.45	2.55	2.47	2.48	2.38	2.11	2.5	2.325	2.3	1	2700	0.6	
M3-0.5	3.05	2.97	2.95	2.87	2.57	3.0	2.775	2.75	1.8	4000	1	
M3.5-0.6	3.58	3.48	3.46	3.36	3.00	3.5	3.230	3.2	2.8	5400	1.6	
M4-0.7	4.07	3.99	3.93	3.85	3.39	4.0	3.680	3.65	4.1	7000	2.4	
M5-0.8	5.08	5.00	4.92	4.84	4.30	5.0	4.630	4.6	8.7	11,400	4.7	
M6-1.0	6.10	5.97	5.90	5.77	5.13	6.0	5.530	5.5	15	16,000	8	
M8-1.25	8.13	7.97	7.88	7.72	6.91	8.0	7.436	7.4	37	29,000	20	
Tolerance on Length		3-6mm: ±0.375			over 6-10mm: ±0.45			over 10-18mm: ±0.55				
		over 18-30mm: ±0.65			over 30 - 50mm: ±0.80			over 50-80: ±0.95				

Description	A trilobular thread forming screw with a machine screw's thread pitch. As each lobe of the screw moves through the pilot hole in the nut material, it forms and work hardens the nut thread metal, producing an uninterrupted grain flow.	
Applications/ Advantages	For use in drilled, punched or cored holes in ductile metals and punch extruded metals. They provide superior prevailing torque than can be achieved with most locking screws. Eliminates chips that result from using thread cutting screws. Requires low drive torque and provides excellent resistance to vibrational loosening. Since these thread rolling screws are case hardened, it is not recommended they be used in die-cast or extruded aluminum or zinc.	Can be used to roll threads in aluminum or non-ferrous materials.
Material	<i>Carbon Steel</i> AISI 1022 Steel	<i>Stainless</i> A2 Stainless Steel
Surface Hardness	450 HV 0.3 Min.	
Case Depth	M2 & M2.5: 0.05-0.15 mm M3 & M3.5: 0.07-0.18 mm M4 & M5: 0.10-0.25 mm M6 & M8: 0.15-0.28 mm	
Core Hardness	M2 - M3.5: 290 - 370 HV 5 M4 & larger: 290 - 370 HV 10	
Torsional Strength	Torque required to cause failure shall be equal to or greater than breaking torque values shown in above table.	
Tensile Strength	Tensile force required to cause failure shall be equal to or greater than breaking force values shown in above table.	
Plating	Thread rolling screws shall have a zinc finish with a wax coating. For more details see Appendix-A.	Stainless thread-rolling screws are typically passivated with a wax coating.

Thread Rolling Screws
Head Dimensions to DIN 965 & 7985

THREAD FORMING SCREWS

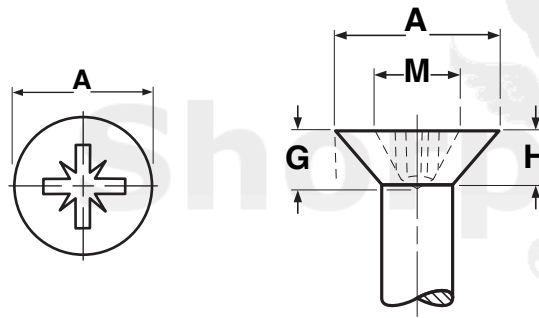

METRIC - TYPE Z (1A) FLAT HEADS FOR TAPPING SCREWS								DIN 965
Nominal Size	A		H		M	G		Drive Size
	Head Diameter		Head Height		Recess Diameter	Recess Penetration		
	Max	Min	Max	Ref	Max	Min		
M2	3.80	3.50	1.20	2.2	1.17	0.92	1	
M2.5	4.7	4.4	1.5	2.5	1.47	1.22	1	
M3	5.6	5.3	1.65	2.8	1.73	1.48	1	
M4	7.5	7.14	2.2	4	2.06	1.60	2	
M5	9.2	8.84	2.5	4.4	2.51	2.05	2	
M6	11	10.57	3	6.1	2.92	2.46	3	

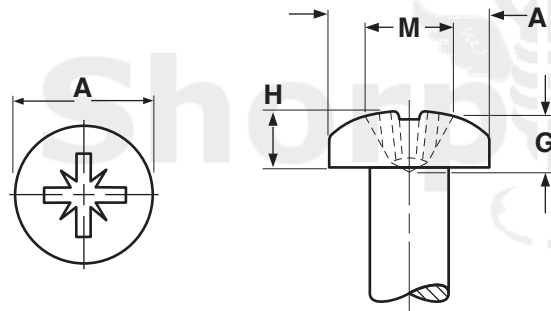

METRIC - TYPE Z (1A) PAN HEADS FOR TAPPING SCREWS								DIN 7985
Nominal Size	A		H		M	G		Drive Size
	Head Diameter		Head Height		Recess Diameter	Recess Penetration		
	Max	Min	Max	Min	Ref	Max	Min	
M2	4.00	3.70	1.72	1.48	2.4	1.17	0.92	1
M2.5	5.00	4.70	2.12	1.88	2.6	1.47	1.22	1
M3	6.00	5.70	2.52	2.28	3.0	1.73	1.48	1
M4	8.00	7.64	3.25	2.95	4.3	2.06	1.60	2
M5	10.00	9.64	3.95	3.65	5.0	2.51	2.05	2
M6	12.0	11.57	4.75	4.45	6.8	2.92	2.46	3

THREAD FORMING SCREWS

**DIN 7500 Thread Rolling Screw
Hole Size Data**

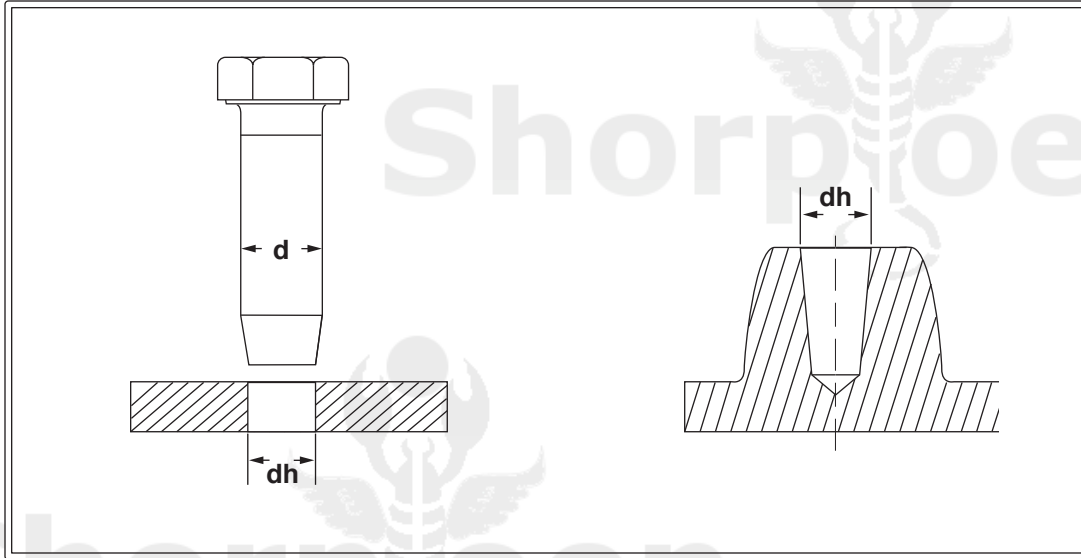

GUIDELINE VALUES FOR HOLE DIAMETERS USING DIN 7500 THREAD ROLLING SCREWS																DIN 7500	
Thread Size	M2		M2.5		M3		M3.5		M4		M5		M6		M8		
Material thickness or length of engagement	Hole Diameter (dh)																
	Max	Min	Max	Min	Max	Min	Max	Min	Max	Min	Max	Min	Max	Min	Max	Min	
0.8	1.86	1.8	2.31	2.25													
0.9	1.86	1.8	2.31	2.25													
1	1.86	1.8	2.31	2.25	2.76	2.7	3.205	3.13									
1.2	1.86	1.8	2.31	2.25	2.76	2.7	3.235	3.16									
1.5	1.86	1.8	2.31	2.25	2.76	2.7	3.235	3.16	3.675	3.6	4.575	4.5					
1.6	1.86	1.8	2.31	2.25	2.76	2.7	3.265	3.19	3.675	3.6	4.575	4.5					
1.7	1.86	1.8	2.31	2.25	2.76	2.7	3.265	3.19	3.675	3.6	4.575	4.5					
1.8	1.86	1.8	2.31	2.25	2.81	2.75	3.265	3.19	3.675	3.6	4.575	4.5					
2	1.86	1.8	2.31	2.25	2.81	2.75	3.265	3.19	3.675	3.6	4.575	4.5	5.475	5.4			
2.2	1.91	1.85	2.31	2.25	2.81	2.75	3.265	3.19	3.675	3.6	4.575	4.5	5.475	5.4	8.15	7.25	
2.5	1.91	1.85	2.31	2.25	2.81	2.75	3.315	3.24	3.725	3.65	4.575	4.5	5.475	5.4	8.15	7.25	
3	1.91	1.85	2.36	2.3	2.81	2.75	3.315	3.24	3.725	3.65	4.575	4.5	5.525	5.45	8.15	7.25	
3.2	1.91	1.85	2.36	2.3	2.81	2.75	3.315	3.24	3.725	3.65	4.625	4.55	5.525	5.45	8.15	7.25	
3.5	1.91	1.85	2.36	2.3	2.81	2.75	3.315	3.24	3.725	3.65	4.625	4.55	5.525	5.45	8.15	7.25	
4	1.91	1.85	2.36	2.3	2.81	2.75	3.345	3.27	3.725	3.65	4.625	4.55	5.525	5.45	8.2	7.3	
5			2.36	2.3	2.81	2.75	3.345	3.27	3.775	3.7	4.675	4.6	5.525	5.45	8.3	7.4	
5.5					2.81	2.75	3.345	3.27	3.775	3.7	4.675	4.6	5.575	5.5	8.3	7.4	
6					2.81	2.75	3.345	3.27	3.775	3.7	4.675	4.6	5.575	5.5	8.3	7.4	
6.3									3.775	3.7	4.725	4.65	5.575	5.5	8.3	7.4	
6.5									3.775	3.7	4.725	4.65	5.575	5.5	8.3	7.4	
7									3.775	3.7	4.725	4.65	5.575	5.5	8.4	7.5	
7.5									3.775	3.7	4.725	4.65	5.575	5.5	8.4	7.5	
8 thru 10											4.725	4.65	5.725	5.65	8.4	7.5	

NOTE:
The values listed above are assigned to various materials and lengths of engagement and should be used as guidelines.