

NUTS

SPRING NUTS

Cage Style

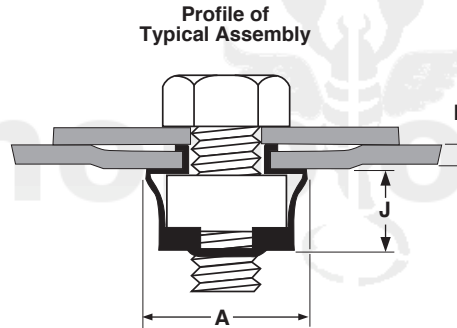
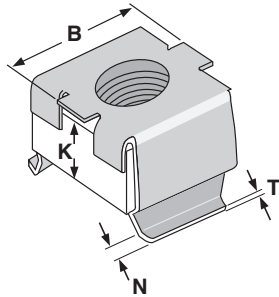

| CAGE NUTS | | | | | | | | | | | | | Tinnerman® Palnut | |
|------------|----------------------|------------|---------------------|------|------------------------|-------------|------|------------|------|--------------------|---------------|-------------|-------------------|--|
| Screw Size | Part Numbers (Steel) | | B | | A | J | | N | | T | K | P | | |
| | Kanebridge | Tinnerman® | Cage Width (Static) | | Cage Width (Assembled) | Cage Height | | Foot Width | | Material Thickness | Nut Thickness | Panel Range | | |
| | | | Max | Min | Min | Max | Min | Max | Min | Ref | Ref | Max | Min | |
| 6-32 | 06NCAG 0608NCAG | 7931-632 | .530 | .510 | .540 | .260 | .240 | .070 | .050 | .020 | .156 | .063 | .025 | |
| 8-32 | 08NCAG | 7931-832 | .530 | .510 | .531 | .260 | .240 | .070 | .050 | .020 | .156 | .063 | .025 | |
| 8-32 | 08-064NCAG | 7941-832 | .530 | .510 | .475 | .265 | .235 | .070 | .050 | .020 | .156 | .105 | .064 | |
| 10-24 | 10NCAG | 7941-1024 | .530 | .510 | .531 | .260 | .240 | .070 | .050 | .020 | .156 | .105 | .064 | |
| 10-24 | 10-025NCAG | 7931-1024 | .530 | .510 | .475 | .265 | .235 | .070 | .050 | .020 | .156 | .063 | .025 | |
| 10-32 | 11NCAG | 7931-1032 | .530 | .510 | .531 | .260 | .240 | .070 | .050 | .020 | .156 | .063 | .025 | |
| 10-32 | 11-064NCAG | 98579-1032 | .530 | .510 | .525 | .260 | .240 | .070 | .050 | .020 | .156 | .105 | .064 | |
| 10-32 | 11-093NCAG | 7951-1032 | .530 | .510 | .525 | .260 | .240 | .070 | .050 | .020 | .156 | .126 | .093 | |
| 12-24 | 12NCAG | 7941-1224 | .530 | .510 | .531 | .260 | .240 | .070 | .050 | .020 | .156 | .105 | .064 | |
| 1/4-20 | 14NCAG | 7988-1420 | .530 | .510 | .531 | .260 | .240 | .070 | .050 | .020 | .187 | .063 | .025 | |
| 1/4-20 | 14-064NCAG | 98580-1420 | .530 | .510 | .525 | .260 | .240 | .070 | .050 | .020 | .187 | .105 | .064 | |
| 1/4-20 | 14-093NCAG | 7956-1420 | .530 | .510 | .525 | .260 | .240 | .070 | .050 | .020 | .187 | .126 | .093 | |
| 5/16-18 | 31NCAG | 7957-5618 | .728 | .650 | .734 | .310 | .290 | .110 | .090 | .025 | .218 | .126 | .093 | |
| 5/16-18 | 31-057NCAG | - | .670 | .650 | .734 | .310 | .290 | .110 | .090 | .025 | .218 | .092 | .057 | |
| 3/8-16 | 37NCAG | 7937-3816 | .670 | .650 | .734 | .310 | .290 | .110 | .090 | .025 | .218 | .056 | .028 | |
| 3/8-16 | 37-057NCAG | 7953-3816 | .670 | .650 | .700 | .310 | .290 | .110 | .090 | .025 | .218 | .092 | .057 | |
| 3/8-16 | 37-.093NCAG | 7957-3816 | .670 | .650 | .700 | .310 | .290 | .110 | .090 | .025 | .218 | .126 | .093 | |
| 1/2-13 | 50NCAG | 7968-1213 | .880 | .860 | .828 | .420 | .400 | .120 | .100 | .025 | .304 | .092 | .059 | |

| | | | | |
|---------------------------------|--|---|--|---|
| Description | A free floating square nut retained within a spring steel cage. The cage has two retaining legs on the same side of the nut, positioned 180° from each other, that hold the nut in place at panel edges or center panel locations. | | | |
| Applications/ Advantages | More economical and easier to install than other heavy duty nuts for blind side applications. Free floating nut will compensate for poorly aligned holes. The square cage design keeps the nut from rotating during tightening. Cage nuts are successfully used in heavy duty farm machinery, rail cars, home entertainment components and heating equipment among other applications. | | | |
| Material | Steel | | Stainless | |
| | Cage: SAE 1050 - 1065 spring steel | Nut: 6-32 thru 1/4-20: SAE 1108 or equivalent steel 5/16-18 & 3/8-16: SAE 1018 or equivalent steel 1/2-13: SAE 1108 or equivalent steel | Cage: Class 304 3/4-hard stainless steel | Nut: Class 304 J3 stainless steel |
| Heat Treatment | Parts are quenched from the proper austenitizing temperature directly into a salt bath at between 590°F and 710°F. Parts are held at this quench temperature for a recommended period. Parts are then removed from the salt quenched and air cooled to room temperature. | | | - |
| Hardness | Rockwell C 44 - 51 | | | - |
| Plating | Steel Cage nuts are typically supplied with a zinc plating. | | Stainless Cage nuts are usually supplied plain. | |

Tinnerman® is a registered trademark of A.Raymond ET CIE. Kanebridge's cage nuts are not manufactured by or connected with the producers of Tinnerman® nuts.

Cage Style—Hole Sizes **SPRING NUTS**

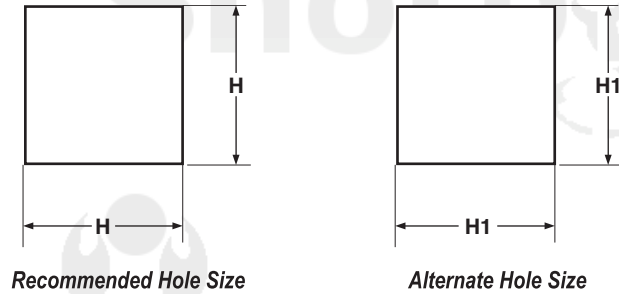

| CAGE NUTS | | | | | | Tinnerman® Palnut | |
|------------|----------------------|------------|-------------------------|------|-----------------------|----------------------|--|
| Screw Size | Part Numbers (Steel) | | H | | H1 | | |
| | Kanebridge | Tinnerman® | Recommended Hole Layout | | Alternate Hole Layout | | |
| | | | Max | Min | | | |
| 6-32 | 06NCAG 0608NCAG | 7931-632 | .380 | .375 | .348 | .343 | |
| 8-32 | 08NCAG | 7931-832 | .380 | .375 | .348 | .343 | |
| 8-32 | 08-064NCAG | 7941-832 | .380 | .375 | .348 | .343 | |
| 10-24 | 10NCAG | 7941-1024 | .380 | .375 | .348 | .343 | |
| 10-24 | 10-025NCAG | 7931-1024 | .380 | .375 | .348 | .343 | |
| 10-32 | 11NCAG | 7931-1032 | .380 | .375 | .348 | .343 | |
| 10-32 | 11-064NCAG | 98579-1032 | .380 | .375 | .348 | .343 | |
| 10-32 | 11-093NCAG | 7951-1032 | .380 | .375 | .348 | .343 | |
| 12-24 | 12NCAG | 7941-1224 | .380 | .375 | .348 | .343 | |
| 1/4-20 | 14NCAG | 7988-1420 | .380 | .375 | .348 | .343 | |
| 1/4-20 | 14-064NCAG | 98580-1420 | .380 | .375 | .348 | .343 | |
| 1/4-20 | 14-093NCAG | 7956-1420 | .380 | .375 | .348 | .343 | |
| 5/16-18 | 31NCAG | 7957-5618 | .508 | .503 | .465 | .460 | |
| 5/16-18 | 31-057NCAG | - | .508 | .503 | .465 | .460 | |
| 3/8-16 | 37NCAG | 7937-3816 | .508 | .503 | .465 | .460 | |
| 3/8-16 | 37-.057NCAG | 7953-3816 | .508 | .503 | .465 | .460 | |
| 3/8-16 | 37-.093NCAG | 7957-3816 | .508 | .503 | .465 | .460 | |
| 1/2-13 | 50NCAG | 7968-1213 | .593 | .588 | .578 | .573 | |

Tinnerman® is a registered trademark of A.Raymond ET CIE. Kanebridge's cage nuts are not manufactured by or connected with the producers of Tinnerman® nuts.