

Oval HEAD DIMENSIONS

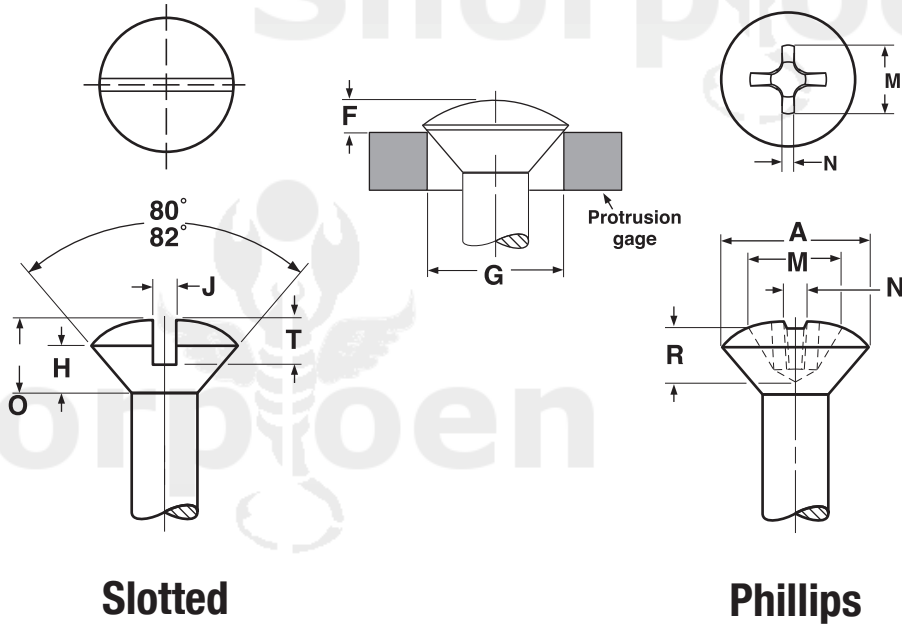

Slotted

Phillips

OVAL HEADS FOR SELF-TAPPING SCREWS															ASME B18.6.3-2013
Nominal Size	A		H	O	J		T		M	R	N	F		G	Phillips Driver Size
	Head Diameter		Height of Head		Width of Slot		Depth of Slot		Dimensions of Recess			Protrusion Above Gaging Diameter		Gaging Diam.	
	Max	Min	Max	Max	Max	Min	Max	Min	Diam	Depth	Width	Max	Min		
					Side	Total			Ref	Ref	Ref				
0	.112	.096	.035	.056	.023	.016	.030	.025	.068	.036	.014	.047	.031	.078	0
1	.137	.120	.043	.068	.026	.019	.038	.031	.070	.039	.015	.053	.035	.101	0
2	.162	.144	.051	.080	.031	.023	.045	.037	.106	.060	.018	.058	.039	.124	1
3	.187	.167	.059	.092	.035	.027	.052	.043	.118	.072	.019	.064	.044	.148	1
4	.212	.191	.067	.104	.039	.031	.059	.049	.130	.086	.019	.069	.048	.172	1
5	.237	.215	.075	.116	.043	.035	.067	.055	.152	.073	.028	.075	.053	.196	2
6	.262	.238	.083	.128	.048	.039	.074	.060	.172	.092	.030	.080	.057	.220	2
7	.287	.262	.091	.140	.048	.039	.081	.066	.176	.098	.030	.085	.062	.243	2
8	.312	.285	.100	.152	.054	.045	.088	.072	.186	.107	.031	.091	.066	.267	2
10	.362	.333	.116	.176	.060	.050	.103	.084	.202	.125	.033	.102	.075	.313	2
12	.412	.380	.132	.200	.067	.056	.117	.096	.264	.140	.038	.113	.084	.362	3
14	.462	.427	.148	.224	.075	.064	.132	.108	.282	.152	.039	.125	.093	.410	3
1/4	.477	.442	.153	.232	.075	.064	.136	.112	.284	.160	.040	.129	.095	.424	3
5/16	.597	.556	.191	.290	.084	.072	.171	.141	.384	.226	.065	.155	.117	.539	4
3/8	.717	.670	.230	.347	.094	.081	.206	.170	.404	.245	.068	.182	.139	.653	4
7/16	.760	.715	.223	.345	.094	.081	.210	.174	.416	.257	.070	.195	.150	.690	4
1/2	.815	.765	.223	.354	.106	.091	.216	.176	.430	.271	.071	.212	.163	.739	4