

Trilobular Pan
External Tooth SEMS

THREAD ROLLING

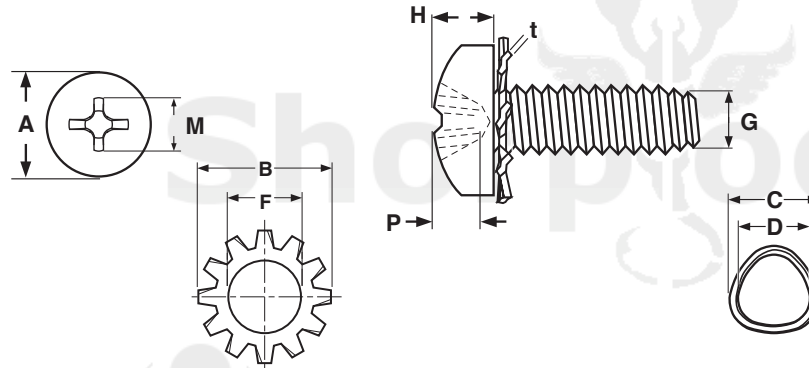

TRILOBULAR THREAD ROLLING SCREW EXTERNAL TOOTH SEMS, PAN PHILLIPS

Nominal Screw Size & Threads per Inch	A		H		B		F		t		C		D		G	M	P		Phillips Driver Size
	Head Diameter		Head Height		Washer Outside Diam		Washer Inside Diam		Washer Material Thickness		Circumscribing Circle Diam		Measurement Across Center		Point Diam of Circumscribing Circle	Drive Diam.	Gauge Penetration		
	Max	Min	Max	Min	Max	Min	Max	Min	Max	Min	Max	Min	Max	Min	Max	Ref	Max	Min	
4-40	.219	.204	.080	.069	.230	.219	.104	.100	.018	.012	.114	.110	.110	.105	.090	.115	.071	.053	1
6-32	.270	.255	.097	.086	.287	.269	.126	.123	.022	.016	.141	.134	.135	.128	.111	.159	.080	.055	2
8-32	.321	.305	.115	.104	.319	.304	-	-	.023	.018	.167	.160	.161	.154	.137	.177	.097	.071	2
10-24	.372	.356	.133	.121	.380	.364	-	-	.024	.018	.194	.187	.185	.178	.152	.193	.113	.089	2
10-32	.372	.356	.133	.121	.380	.364	-	-	.024	.018	.193	.186	.187	.180	.163	.193	.113	.089	2
Tolerance on Length										+ 0, -0.03									

Description	Trilobular thread rolling screw with a gently rounded top surface and a captive, free-spinning external tooth lockwasher manufactured as one assembly. As each lobe of the screw moves through the pilot hole in the nut material, it forms and work-hardens the nut thread metal, producing an uninterrupted grain flow.	
Applications/ Advantages	For drilled, punched or corrod holes in all ductile metals and punch extruded metals. Eliminates chips, requires low drive torque and provides excellent resistance to vibrational loosening. The washer/screw assembly makes this a locking screw with the washer providing the locking action. Machine pre-assembly provides cost savings to the end user.	
Material	Screw 1022 or equivalent carbon steel	Washer 1050 or equivalent spring steel
Heat Treatment	Screws shall be quenched in liquid and then tempered by reheating to 650°F minimum.	
Case Hardness	Rockwell C45 minimum	
Case Depth	2-56 through 6-32 diameters: .002 - .007 8-32 through 10-32 diameters: .004 - .009	
Core Hardness (after tempering)	Rockwell C28-38	Rockwell C40 - 50
Plating	See Appendix-A for information on the plating of trilobular thread rolling SEMS screws.	